

## Stepping Motor Drive IC AN8495SB

### Overview

AN8495SB is a stepping-motor-driving IC, created by using a D-MOS process, and provides a maximum output of 30V at 1.5A. By the PWM drive and 2-bit constant-current-chopping-drive method, the winding 1-2 phase drive is possible.

### Feature

- 4-phase input (W1-2 phase excitation)
- 2-bit current level switching.
- Built-in noise canceller.
- Built-in phase-change thru-current protection function.
- Built-in flywheel diode

### Applications

- Printer , FAX ,PPC

### Recommended Operating Range

Operating supply voltage range	VCC	4.75V to 5.25V
	VM	18.0V to 28.0V

### Electrical Characteristics (Ta=25°C±2°C, Vcc=5.0V, VM=24V)

Parameter	Symbol	Condition	min	typ	max	unit
<b>Power block</b>						
Output saturation voltage H	VOH	I = -1.0A	VM-0.75	VM-0.5	-	V
Output saturation voltage L	VOL	I = 1.0A	-	0.65	0.98	V
Flywheel diode forward voltage	VDI	I = 1.0A	0.5	1.0	1.5	V
<b>Control block</b>						
PWM frequency	fPWM		50.2	67	83.8	kHz
Comparator threshold H(100%)	VTH	IN0=IN1=0V, IN2=IN3=0V	0.479	0.503	0.528	V
Comparator threshold C(67%)	VTC	IN0=5V, IN1=0V, IN2=5V, IN3=0V	0.305	0.330	0.356	V
Comparator threshold L(33%)	VTL	IN0=0V, IN1=5V, IN2=0V, IN3=5V	0.151	0.167	0.185	V

The products and specification are subject to change without any notice. Please ask for the latest Product Standards to guarantee the satisfaction of your product requirements.

Semiconductor Company, Matsushita Electric Industrial Co., Ltd.

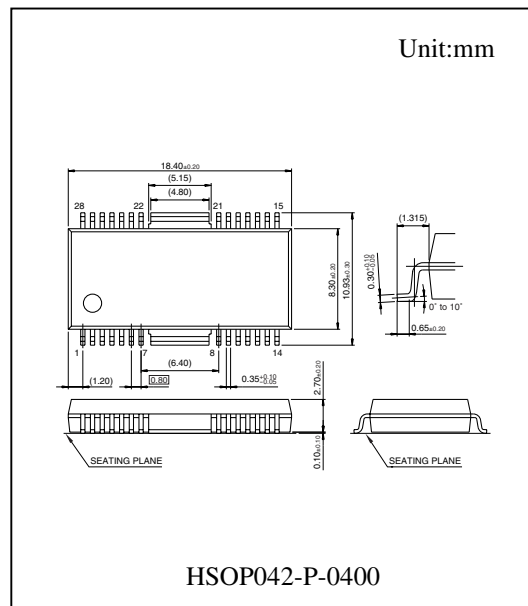

## ■ Block Diagram

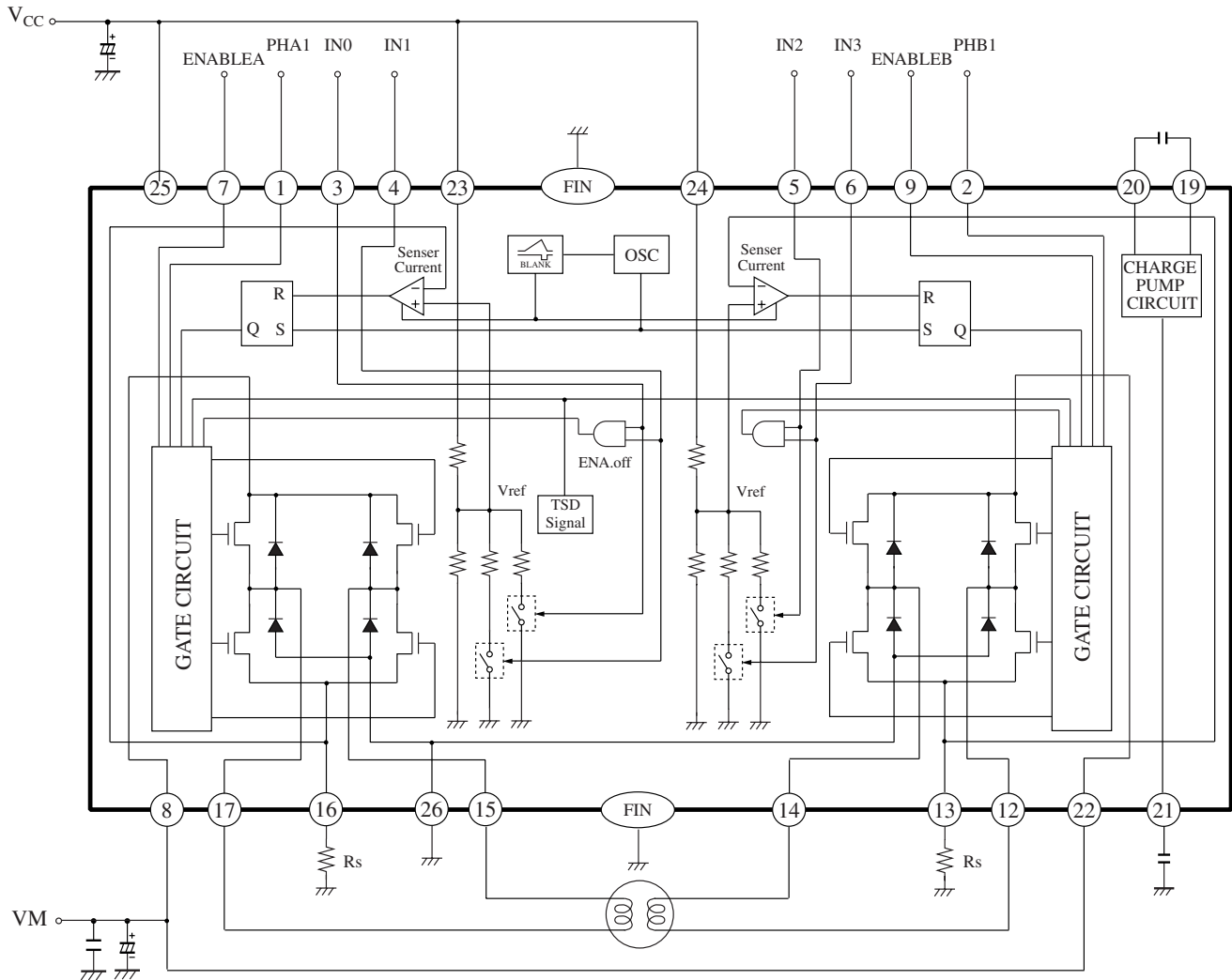

\* A voltage is applied externally to Terminals PHA1, PHB1, IN0 to 3, ENABLEA, ENABLEB, VREFA and VREFV, and may cause an overcurrent. To protect the device from overcurrent, insert an overcurrent protective resistor (1K $\Omega$  or over).

## ■ Pin Descriptions

Pin No.	Symbol	Function	Pin No.	Symbol	Function
1	PHA1	A phase changeover terminal	16	RCSA	A phase current detector
2	PHB1	B phase changeover terminal	17	AOUT1	Motor drive A phase output 1
3	IN0	A phase output torque control 1	18	N.C	-
4	IN1	A phase output torque control 2	19	BC1	Capacitor for charge pump circuit 1
5	IN2	B phase output torque control 1	20	BC2	Capacitor for charge pump circuit 2
6	IN3	B phase output torque control 2	21	VPUMP	Charge pump circuit output
7	ENABLEA	A phase start/stop signal input	22	VM2	Supply terminal for Motor 2
8	VM1	Supply terminal for Motor 1	23	VREFA	A phase torque ref. voltage input
9	ENABLEB	B phase start/stop signal input	24	VREFB	B phase torque ref. voltage input
10	N.C	-	25	VCC	Supply terminal
11	N.C	-	26	GND	Signal GND
12	BOUT2	Motor drive B phase output 2	27	N.C	-
13	RCSB	B phase current detector	28	N.C	-
14	BOUT1	Motor drive B phase output 1	FIN	GND	Signal GND
15	AOUT2	Motor drive A phase output 2			